

LTD0215 Direct Drive

Bearing assemblies with direct drive are suitable for applications where high performance and low space requirements are important criteria. The integration of the drive into the bearing housing means that wear-prone assemblies for transmitting drive power, such as toothed belts, shafts or chains, can be dispensed with. This reduces the required drive energy and also benefits more accurate positioning.

Technical data

Material

C45N (optionally aluminium)

Operating temperature

-10 °C to +80 °C

Mounting position

Any

Lubricant

With bearing grease via grease nipples

Options

Absolute measuring system, axial cable outlet, cables, water-cooling



LTD0215

Name	KKØ mm	Load ratings kN				Torque Nm		Power A		Speed 1/min. nmax	Weight kg	Engine type	Order no.	CAD Cadenas
		Coa	Cor	Ca	Cr	MNom	MPeak	INom	IPeak					
LTD0215	215	128	60	26	22	26,4	105	3,1	12,8	640	21	TI240-181-025	609885	↓

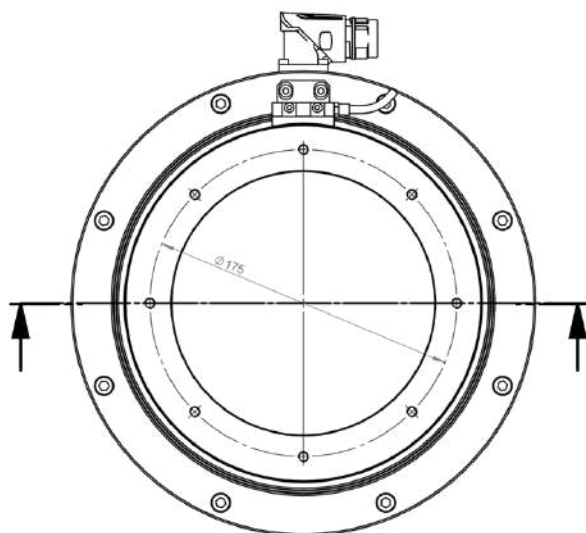
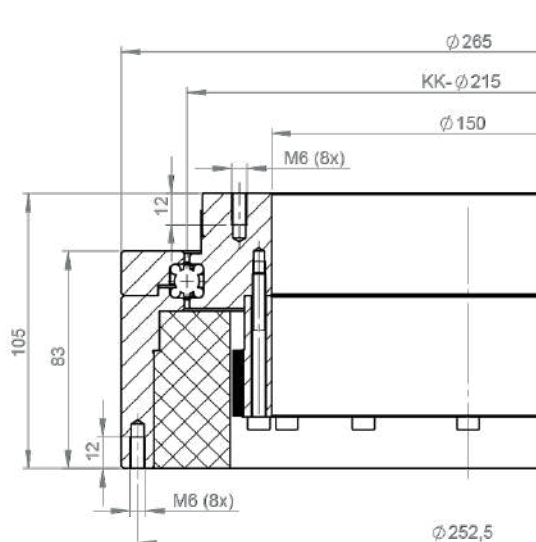

Power Comparison

Power comparison			LTD-0100	LTD-0215	LTD-0320	LTD-0385
Nominal Data (Air cooling)						
Nominal Torque	TNomAC	Nm	4,5	26,4	77	118
Nominal Current	INomAC	Arms	1,8	3,1	4,3	4,3
Nominal Speed	nNomAC	rpm	2140	640	299	193
Nominal Power	PNomAC	W	1005	1770	2409	2386
Winding Losses ¹	PVNennLk	W	54	131	230	309
Total Losses ²	PDAC	W	96	179	295	357
Holding Torque	THAC	Nm	3,2	18,7	54	83
Holding Current	IHAC	Arms	1,2	2,2	3	3
Peak Data						
Peak Torque	TPeak	Nm	16	105	329	522
Peak Current	IPeak	Arms	7	12,8	21,6	21,7
Speed at Peak Torque	nPeak	U/min	1130	320	126	74
Peak Power	PPeak	W	1897	3526	4343	4049
Winding Losses ¹	PPeak	W	863	2236	5886	7876
Total Losses ²	PDPeak	W	877	2253	5904	7889
Power Data						
Torque Constant	kt	Nm/Arms	2,549	8,51	18,037	27,449
		Vrms/(rad/s)	1,577	5,2	11,094	16,694
BEMF Constant (Phase - Phase)	ke	Vrms(rpm)	0,165	0,545	1,162	1,748
Motor Constant	km	Nm/vW	0,459	1,973	4,483	6,25
Idle Speed	nidle	rpm	2390	727	340	226
max. Speed (Fieldweaking)	nmax	rpm	-	-	-	-
max. Frequenz (Idle)	fmax	Hz	398	254	159	124
max. Frequenz (Fieldweaking)	fmax	Hz	-	-	-	-
DC Bus Voltage	UDC	VDC	560	560	560	560
Ø Resistance per Phase (winding only)	RPh20	Ω	4,419	3,457	3,206	4,285
Ø Inductance per Phase (winding only)	LPh	mH	21,727	19,532	21,071	28,049
electr. Time Constant t=L/R	Tel	ms	4,92	5,65	6,57	6,62
Number of Polepairs	n		10	21	28	33
Winding Connection			Star	Star	Star	Star
Measuring System						
Measuring Method					incremental	
Reference mark					single coded	
Measuring principle					inductive	
Interface					1 Vpp	
Cable length					1 m	
Grating period					1000 µm	
Line count			256	640	938	1200
Interpolation					10-fold	
Number of signal periods			2560	6400	9380	12000
Position error per grating period			±11"	±4,5"	±3"	±2,5"
Grating period accuracy (±10µm arc length)			±51"	±20"	±14"	±11"
Max. scanning frequency					40 kHz	
Voltage supply					4V to 7V DC	
Electrical connection					cable with M23, 12 pin male	

Power Graphs

Speed-Torque-Graph

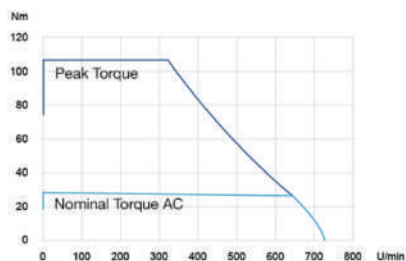

Speed-Power-Graph

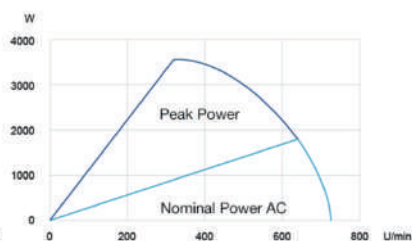

Current-Torque-Graph

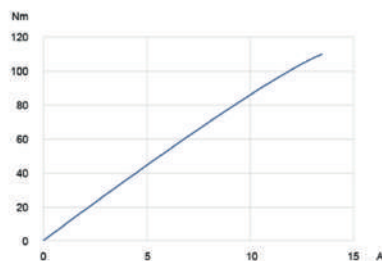

Stator Iron Losses

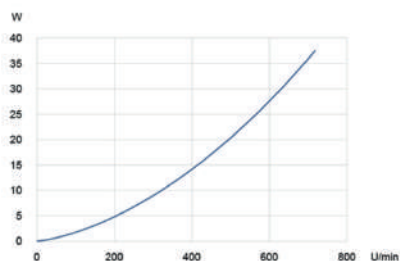

Rotor Losses

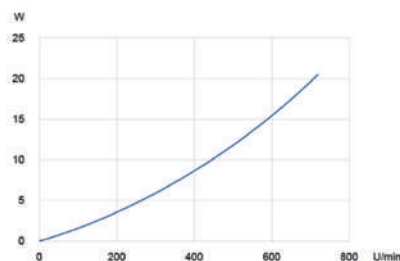

Pin assignment motor

Socket 917, M17x1 (9-pin)

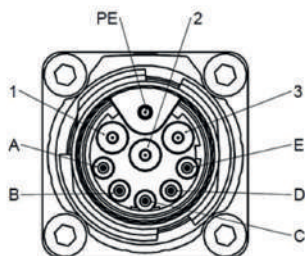

Pin assignment

PIN	Signal	PIN	Signal
1	Phase U	A	PT1000
2	Phase V	B	PT1000
3	Phase W	C	PTC 120°
PE	protective conductor	D	PTC 120°
		E	free

Pin assignment measuring system

03S12 12-pin coupling M23

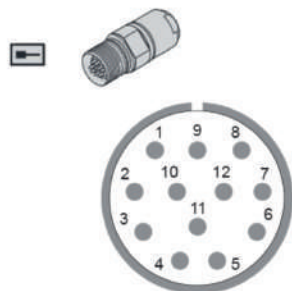

Pin assignment

Power supply	Incremental signals	Other signals
12 Up	5 A+	/ free
2 Sensor Up	6 A-	7 Diag+
10 0 V	8 B+	9 Diag-
11 Sensor 0 V	1 B-	
	3 R+	
	4 R-	

Annotations:

1 Winding Losses are referred to a Coil Temperature of 100°C.

2 The total Losses are made up of: Winding Losses; Stator Iron Losses; Rotor Losses; Calculation of total Losses: Winding Losses + Stator Iron Losses (at speed X) + Rotor Losses (at speed X)

Ensure that your servo drive can handle the Nominal- and Peakcurrent of the Motor. An adjustment of the Speed and DC Bus Voltage can be done after consultation. The nominal data in this datasheet are based on an ambient/coolant temperature of 20°C. The stated nominal Torques are without consideration of friction losses through Bearings or Sealings.

Because the exact duty type depends also on the thermal connection of the motor, the embedded thermal monitoring system has to be analysed and attended. However, attention has to be paid that the temperature sensors do not show the exact temperature of the winding and this could be up to 20 K higher due to thermal capacities. Despite an electrical insulation towards the winding, you are only allowed to connect the sensors to your controller by using a galvanic separation in between.n.